

**vtech**<sup>®</sup>

# User's Manual

**Go! Go! Smart Wheels™**  
*Playtime with miles of learning!*

## Construction Playset

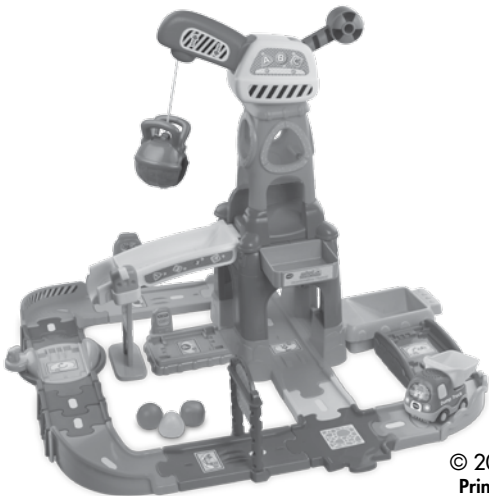

© 2013 VTech  
Printed in China  
91-002859-004 US

Dear Parent,

Welcome to the world of **Go! Go! Smart Wheels™**! We're excited you've decided to ride along with us and explore all that **Go! Go! Smart Wheels™** has to offer. These toys have been designed to give your child a thrilling learning experience with hours and hours of fun as well.

**Go! Go! Smart Wheels™** features vehicles that interact with your child by lighting up, singing and talking, while teaching your child letters and vehicle names (each sold separately). There are other surprises in store, too! With our innovative **SmartPoint™** technology, available exclusively on **Go! Go! Smart Wheels™** playsets (each sold separately), your child will smile as they hear **SmartPoint™** vehicles respond to each unique **SmartPoint™** location with singing, sound effects and fun phrases.

Our **Go! Go! Smart Wheels™** playsets also feature buttons, gears and other mechanical features to encourage the development of your child's fine motor skills. Many of the playsets also have tracks that can be arranged in endless ways, stimulating your child's creativity. In addition, many of the **Go! Go! Smart Wheels™** playsets connect to other playsets in the collection, so there's no end to what your child can do!

With **Go! Go! Smart Wheels™**, it's playtime with miles of learning!

Sincerely,  
Your friends at **VTech®**

To learn more about **VTech®** toys, visit [www.vtechkids.com](http://www.vtechkids.com)

# INTRODUCTION

Thank you for purchasing the **VTech® Go! Go! Smart Wheels™ Construction Playset** learning toy!

Let your little construction worker discover and explore with the **Go! Go! Smart Wheels™ Construction Playset** by **VTech®!** Pick up, sort and dump play pieces into the included dump truck or into the crane tower with its cool rotating crane and working claw, building motor and role-play skills. Move around the site and dump the pieces into the cargo loader. The dump truck or other **SmartPoint™** vehicles (each sold separately) can go into the weigh station and recognize six **SmartPoint™** locations, encouraging first words and language skills. The whistle has blown and it's time to get to work. It's playtime with miles of learning!

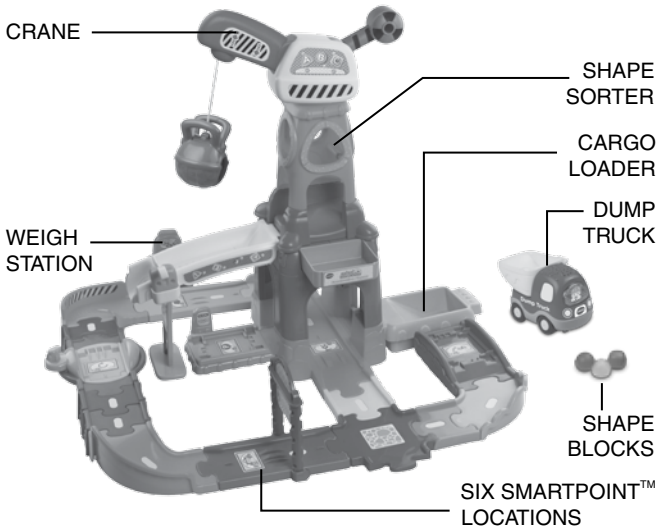

# INCLUDED IN THIS PACKAGE

- One user's manual

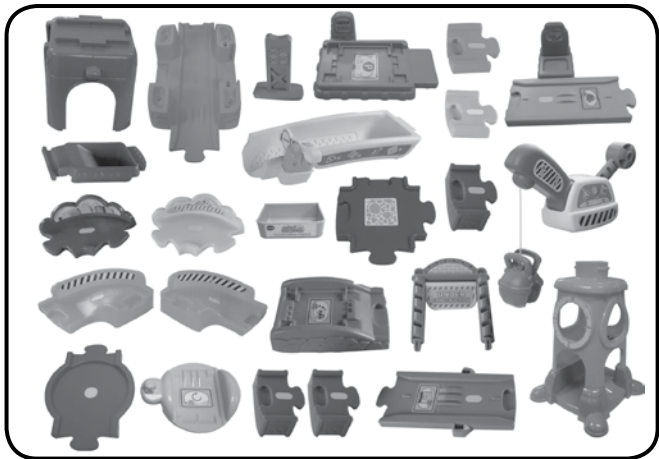

25 track and play pieces



Three shape blocks



One dump truck

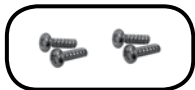

Four screws

## WARNING:

All packing materials, such as tape, plastic sheets, packaging locks and tags are not part of this toy, and should be discarded for your child's safety.

## ATTENTION:

Pour la sécurité de votre enfant, débarrassez-vous de tous les produits d'emballage tels que rubans adhésifs, feuilles de plastique, attaches et étiquettes. Ils ne font pas partie du jouet.

## NOTE:

Please keep this user's manual as it contains important information.

# ASSEMBLY INSTRUCTIONS

With the VTech® Go! Go! Smart Wheels™ Construction Playset, safety comes first. To ensure your child's safety, adult assembly is required.

1. Attach the crane platform onto its orange **SmartPoint™** base. Turn them over and use a screwdriver to tighten the four screws on the bottom.



2. Insert the cargo chute onto the crane platform by inserting the top end of it into the corresponding groove on the platform. Then, add the support piece to the bottom of the chute.

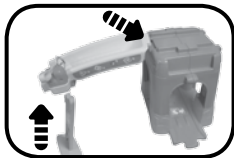

3. Insert the cargo loader onto the crane platform by tilting it and inserting the end of it into the corresponding groove. Insert the gray tray onto the crane platform by sliding the end of it into the corresponding groove on the platform.

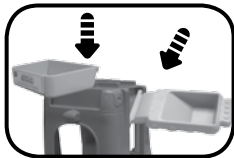

4. Insert the crane onto the crane tower. You will hear it click into place.



5. Insert the crane tower onto the platform. You will hear it click into place.



**Reconfigure the track pieces for more ways to play!**

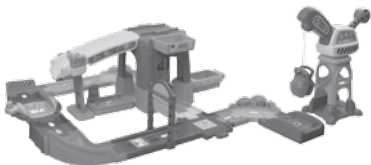

## GETTING STARTED

### BATTERY INSTALLATION

1. Make sure the unit is turned **OFF**.
2. Locate the battery cover on the bottom of the dump truck. Use a coin or a screwdriver to loosen the screw.
3. Install 2 new 'AAA' (AM-4/LR03) batteries following the diagram inside the battery box. (The use of new alkaline batteries is recommended for maximum performance.)
4. Replace the battery cover and tighten the screw to secure.

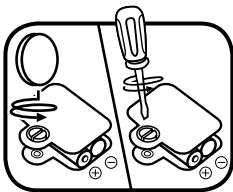



## BATTERY NOTICE

- Use new alkaline batteries for maximum performance.
- Use only batteries of the same or equivalent type as recommended.
- Do not mix different types of batteries: alkaline, standard (carbon-zinc) or rechargeable (Ni-Cd, Ni-MH), or new and used batteries.
- Do not use damaged batteries.
- Insert batteries with the correct polarity.
- Do not short-circuit the battery terminals.
- Remove exhausted batteries from the toy.
- Remove batteries during long periods of non-use.
- Do not dispose of batteries in fire.
- Do not charge non-rechargeable batteries.
- Remove rechargeable batteries from the toy before charging (if removable).
- Rechargeable batteries are only to be charged under adult supervision.

## DUMP TRUCK PRODUCT FEATURES

### 1. ON/OFF SWITCH

To turn the dump truck **ON**, slide the **ON/OFF SWITCH** to the **ON** (  ) position. To turn the dump truck **OFF**, slide the **ON/OFF SWITCH** to the **OFF** (  ) position.

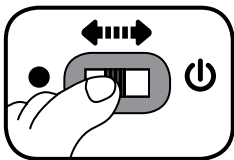

### 2. AUTOMATIC SHUT-OFF

To preserve battery life, the **VTech® Go! Go! Smart Wheels™ Dump Truck** will automatically power-down after approximately 30 seconds without input. The unit only can be turned on again by pressing the light-up driver button or pushing the dump truck quickly.

# DUMP TRUCK ACTIVITIES

1. Slide the **ON/OFF SWITCH** to turn the dump truck **ON**. You will hear dump truck sounds, a song and a phrase. The light will flash with the sounds.

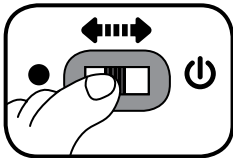

2. Press the **LIGHT-UP BUTTON** to hear dump truck sounds, songs and phrases. The light will flash with sounds.



3. Push the dump truck to hear fun sounds and melodies. While the melody is playing, push the dump truck again to add in fun sounds on top of the melody. The light will flash with sounds.



4. For added fun, the dump truck interacts with the **Go! Go! Smart Wheels™ Construction Playset**. Simply roll the dump truck over one of the construction site's six **SmartPoint™** locations to see the dump truck's light flash and to hear greetings, fun sounds, short tunes and sing-along songs. The dump truck even interacts with other **Go! Go! Smart Wheels™** playsets (each playset sold separately).





If there is no input for approximately 8 seconds, you will hear a phrase and sound effects. After another 8 seconds of no input, a song will play. If there is no input for an additional 8 seconds, the dump truck will play a short tune and then go into sleep mode. The dump truck can be re-activated by pressing the light-up driver button or pushing the dump truck quickly.

## **MELODY LIST**

1. Humpty Dumpty
2. Skip to My Lou
3. Pop! Goes the Weasel
4. Little Boy Blue
5. Hickory Dickory Dock
6. This Old Man

## **SING-ALONG SONG LYRICS**

### **SONG 1**

Rolling in my dump truck,  
carrying a load.

To the construction site,  
it's time to go!

### **SONG 2**

Load my truck, then unload.  
Day and night, to and fro!

### **SONG 3**

1-2-3, my truck's heavy!  
Carrying a load, it's time to go!

# CARE & MAINTENANCE

1. Keep the unit clean by wiping it with a slightly damp cloth.
2. Keep the unit out of direct sunlight and away from any direct heat source.
3. Remove the batteries when the unit will not be in use for an extended period of time.
4. Do not drop the unit on hard surfaces and do not expose the unit to moisture or water.

# TROUBLESHOOTING

If for some reason the program/activity stops working or malfunctions, please follow these steps:

1. Please turn the unit **OFF**.
2. Interrupt the power supply by removing the batteries.
3. Let the unit stand for a few minutes, then replace the batteries.
4. Turn the unit **ON**. The unit should now be ready to play again.
5. If the product still does not work, replace with a new set of batteries.

If the problem persists, please call our Consumer Services Department at 1-800-521-2010 in the U.S. or 1-877-352-8697 in Canada, and a service representative will be happy to help you.

For information on this product's warranty, please call **VTech®** at 1-800-521-2010 in the U.S. or 1-877-352-8697 in Canada.

## IMPORTANT NOTE:

Creating and developing **Infant Learning** products is accompanied by a responsibility that we at **VTech®** take very seriously. We make every effort to ensure the accuracy of the information, which forms the value of our products. However, errors sometimes can occur. It is important for you to know that we stand behind our products and encourage you to call our Consumer Services Department at 1-800-521-2010 in the U.S. or 1-877-352-8697 in Canada, with any problems and/or suggestions that you might have. A service representative will be happy to help you.

## Note:

This equipment has been tested and found to comply with the limits for a Class B digital device, pursuant to Part 15 of the FCC Rules. These limits are designed to provide reasonable protection against harmful interference in a residential installation. This equipment generates, uses and can radiate radio frequency energy and, if not installed and used in accordance with the instructions, may cause harmful interference to radio communications. However, there is no guarantee that interference will not occur in a particular installation. If this equipment does cause harmful interference to radio or television reception, which can be determined by turning the equipment off and on, the user is encouraged to try to correct the interference by one or more of the following measures:

- Reorient or relocate the receiving antenna
- Increase the separation between the equipment and receiver
- Connect the equipment into an outlet on a circuit different from that to which the receiver is connected
- Consult the dealer or an experienced radio/TV technician for help

**Caution:** Changes or modifications not expressly approved by the party responsible for compliance could void the user's authority to operate the equipment.

THIS DEVICE COMPLIES WITH PART 15 OF THE FCC RULES. OPERATION IS SUBJECT TO THE FOLLOWING TWO CONDITIONS:  
(1) THIS DEVICE MAY NOT CAUSE HARMFUL INTERFERENCE, AND  
(2) THIS DEVICE MUST ACCEPT ANY INTERFERENCE RECEIVED, INCLUDING INTERFERENCE THAT MAY CAUSE UNDESIRE OPERATION.

CAN ICES-3 (B)/NMB-3(B)

**CLASS 1  
LED PRODUCT**